

**Shaft plan view**

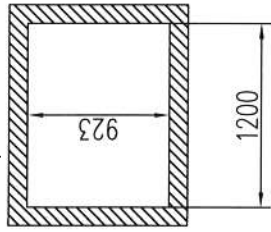

M= An additional 50 mm for clear structural opening is required.

Shaft ceiling with a light.

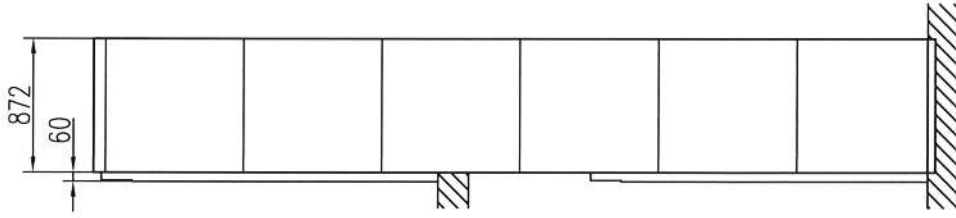

Side B

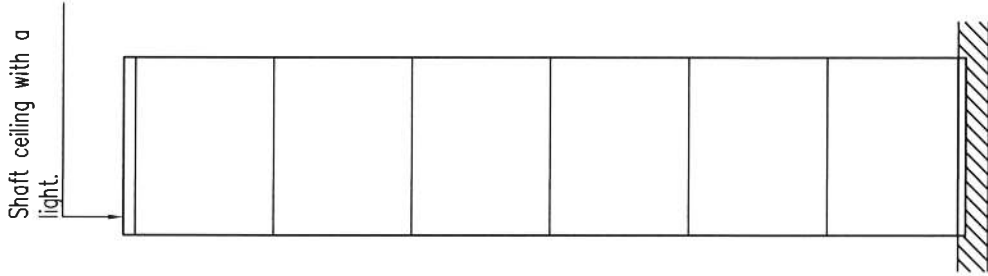

Side C

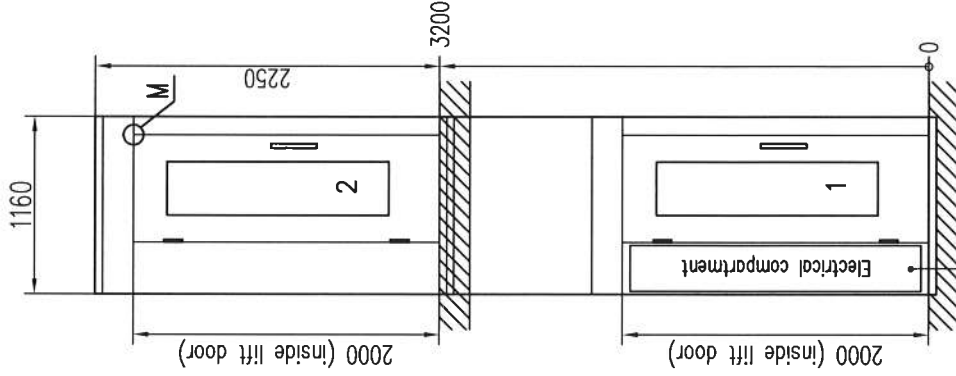

Side A

Access required for compartment cover

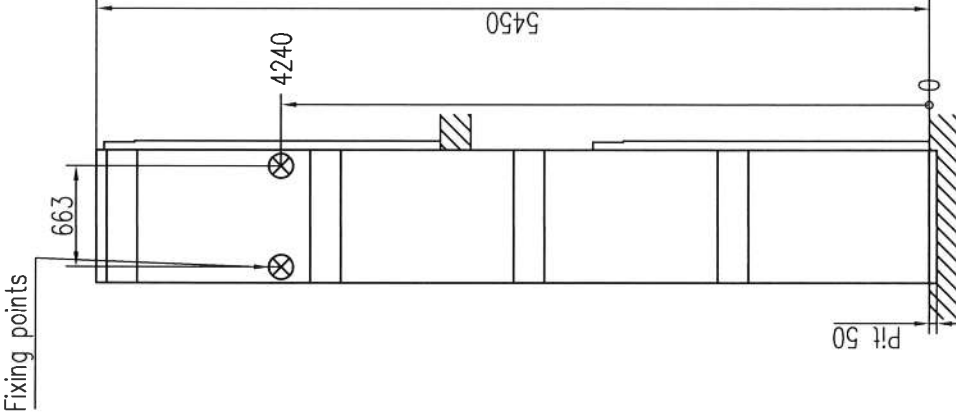

Side D

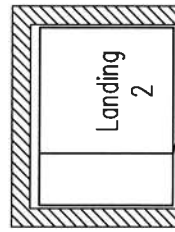

Landing 2

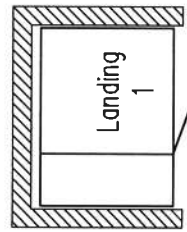

Landing 1

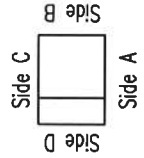

A300S



Shaftwall A300S

Scale	1:33	File name	80954-N
Drawn		Date	12-09-07
Constr.		Desig-nr	
		Sheet	1

PAINT FINISH AND CLEAR DOOR OPENING SIZES ETC.

The platform carriage is powder coat finished in metallic silver, RAL 9006

A complete ready made steel shaft painted in our white colour RAL 9016 (inside/outside) and the corner profiles will be delivered in natural anodised aluminium

The doors and door frames will be delivered in natural anodised aluminium.

Lift internal door opening sizes

Landing	W	H
Landing 1	700	2000
Landing 2	700	2000

Infill between outer wall and platform lift shaft to be built by the builder after the platform lift has been installed.

The platform dimensions

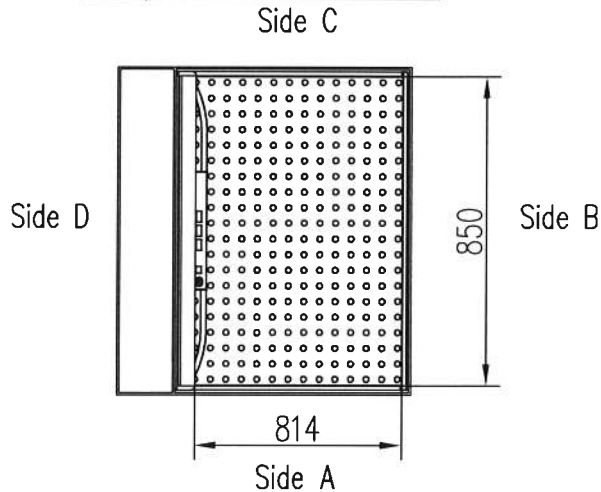

A300S



Drawn

Shaftwall A300S

Scale

File name

80954-N

Constr.

1:33

Date

12-09-07

Dwg-nr

Sheet

2

**CUTOUT SIZES**

**ALTERNATIVE 1 EXISTING SHAFT IN BUILDING.**

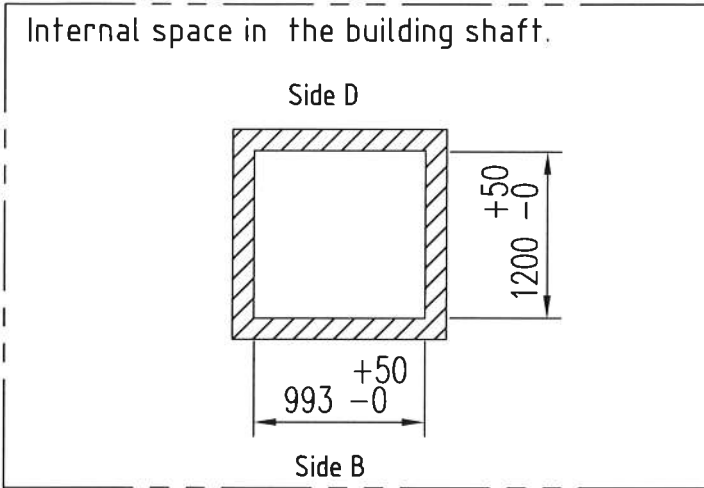

**ALTERNATIVE 2, ONLY CIBES SHAFT IN BUILDING WITH MEZZANINE LANDINGS**

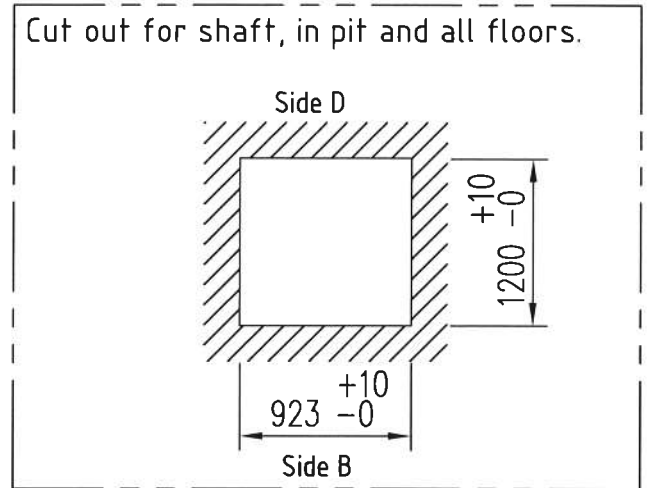

**FLOOR LOADING DETAILS**

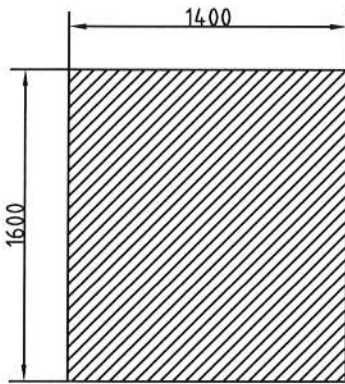

▨ Floor loading in shaded area 8,3 KN /m<sup>2</sup>

Opening for door frame (WxH) at landing specification below.

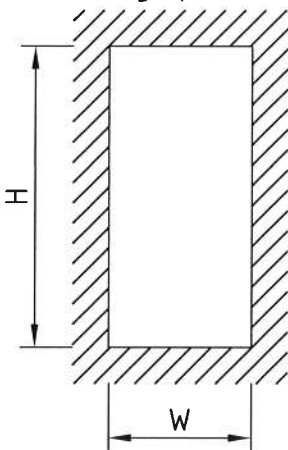

Landing	W	H
Landing 1	1200	2250
Landing 2	1200	2250

**LOCATION OF FIXING BEAMS**

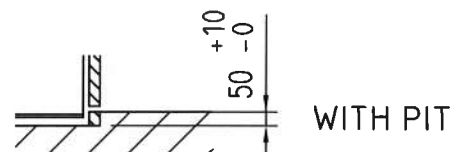
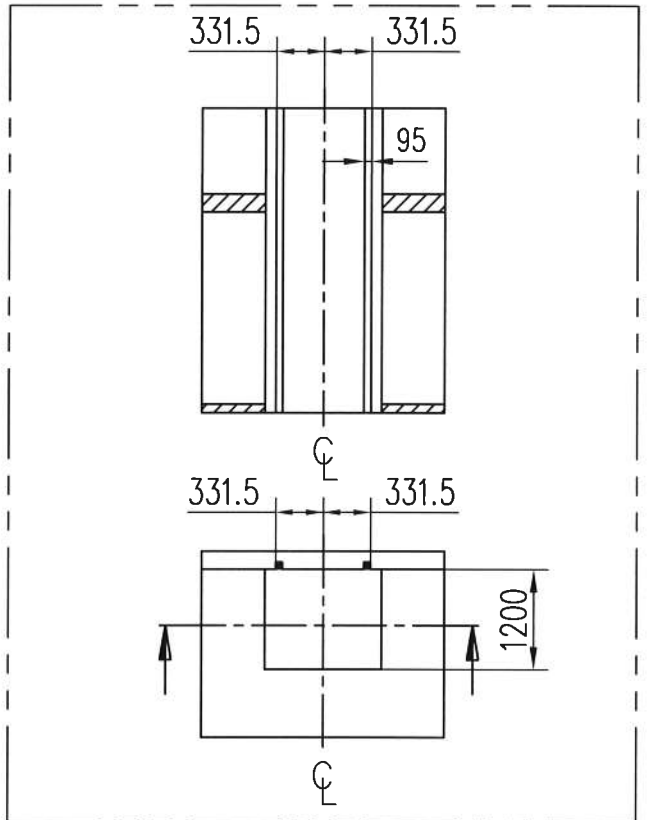



- A300S

ELECTRICS

### Electrical Supply Landing 1

One phase with neutral and earth, 240 V, 16A 2,5mm<sup>2</sup>.  
Places 100mm from shortside and 100 mm up on the wall.

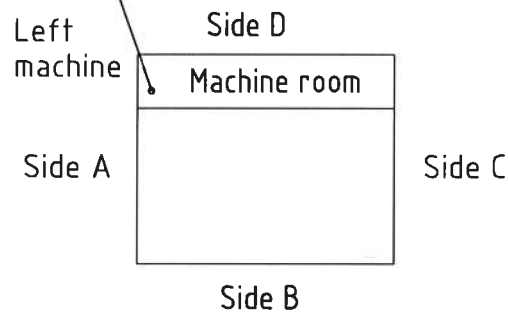

[www.tehportal.com.ua](http://www.tehportal.com.ua)

tel/+3-8-050-585-39-28